

SELCO T-Line Generator Control, Protection and Monitoring

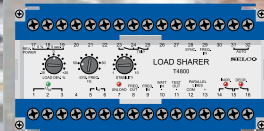

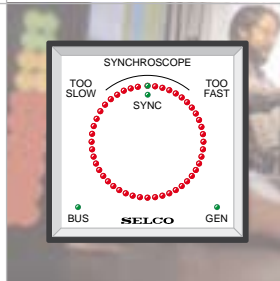
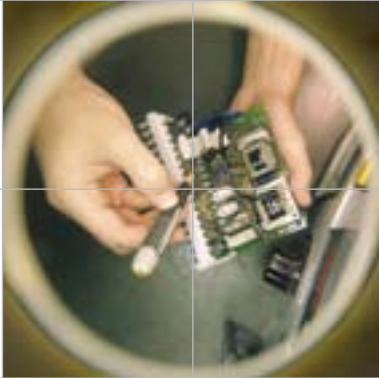

RELIABILITY

Selco T-Line

The Selco T-line offers a complete range of system components for generator control, protection and power monitoring.

The units are for DIN rail mounting or screw mounting in switchboards. Since the units are working on identical principles and have similar design and adjustment schemes, they are easily installed or replaced. All units are available in a number of versions varying in supply voltage and other functions, hence meeting specific customer requirements to a large extent.

Synchronizing and load/power control

The SELCO T-Line range includes various Auto Synchronizers and Load Sharers for load/power control. The Auto Synchronizers perform automatic synchronization of incoming generators in a minimum of time. The Load Sharers provide automatic load sharing and system frequency control for generators running in parallel.

Two solutions are available: One for synchronizing and load sharing on generators with conventional governors (and electronic speed controllers via an intermediate motorized potentiometer). The other for connection directly to all types of electronic speed controllers. For synchronizing SELCO also supplies Synchrosopes for illuminated indication of the phase difference.

Also available is a VAR Load Sharer for automatic load sharing of the reactive power or for power factor control on generators running in parallel with the grid (utility).

Cogeneration Application

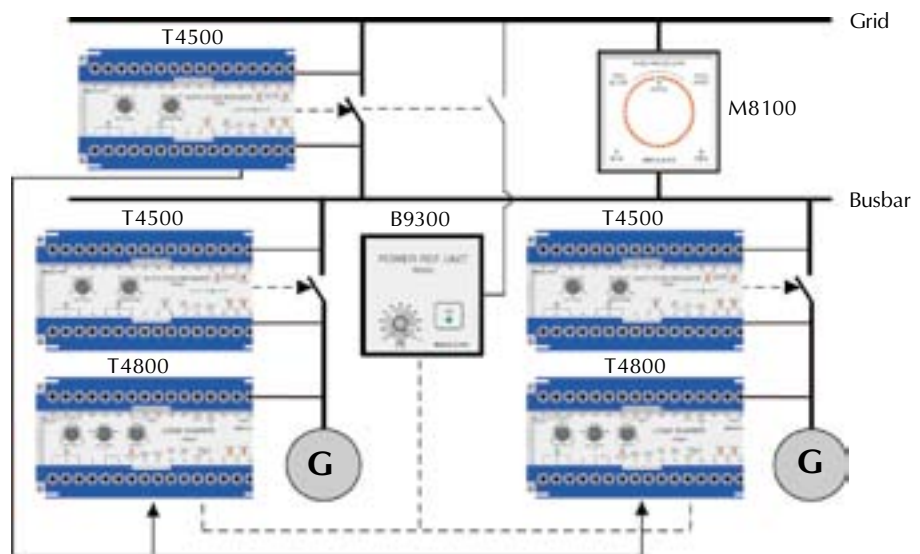

Synchronizing Parallel Running Generators to the Grid or a Shaft Generator

! „We have used SELCO for a number of years now, and frequently use their products as a first choice solution for our various control applications. We find the efficiency of their service a great help during „break-down site“ situations.“

Lee Dainty, Purchaser,
Twyer Instrumentation Control & Switchgear,
United Kingdom

T4000 Auto Synchronizer

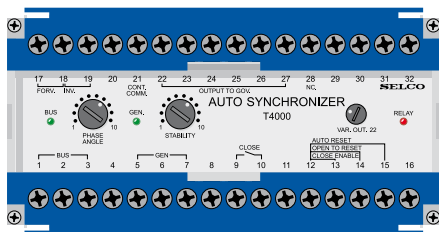

The T4000 performs automatic synchronizing of an incoming generator with *electronic* speed controllers in a minimum of time, by controlling the generator speed and the phase between the generator and the busbar.

The unit has fixed and variable output for adaptation to a wide range of electronic speed controllers.

T4400 Load Sharer

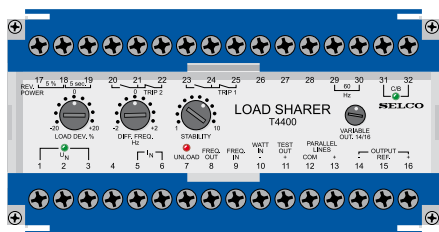

The T4400 is a load sharer for generators with *electronic* speed controllers. It includes a built-in frequency control and an integration function, providing a very high overall stability and compensate for any drift within the engine speed controller.

A soft load/unload function is also provided. When activated, the T4400 will slowly increase or decrease speed to transfer load to or from the generator. A built-in relay can automatically trip the circuit breaker when unload is completed.

The T4400 has a built-in reverse power protection with selectable limit and time delay. One load sharing unit T4400 is required for each diesel generator in parallel operation. The load sharers are interconnected with a 2-wire cable.

When applied with the B9300 Power Reference Unit, one or several generators can be operated in parallel with the grid.

T4500 Auto Synchronizer

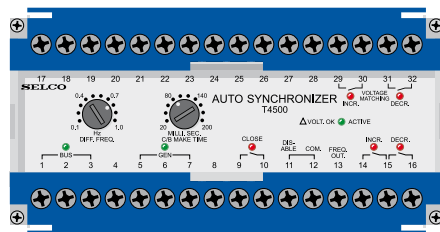

The T4500 performs automatic synchronization of an incoming generator in a minimum of time by controlling the frequency via the electric servomotor on a speed governor or via the E7800 Motorized Potentiometer, or T7900 Electronic Potentiometer.

Among the features it can control the T4800 Load Sharer to e.g. transfer a load from one or several diesel generators operating in parallel with the grid, or on board a ship, to a shaft generator. The frequency will be aligned by the synchronizer through the load sharers. The unit has voltage matching output with adjustable voltage window.

T4800 Load Sharer

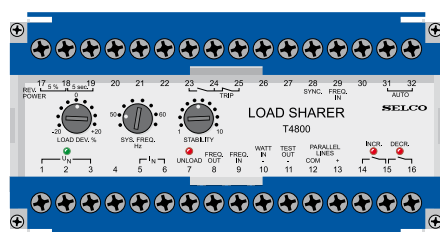

The T4800 provides automatic load sharing and system frequency control of generators running in parallel. The load on each generator is compared with the load of the other generators and adjusted via the electric servomotor on the speed governor or a motorized potentiometer until balance is obtained.

An unloading function is built into the unit to facilitate smooth transfer of the load from a generator before being taken out of service, by an automatic tripping signal to the breaker.

The unit also has reverse power protection. One T4800 unit is required for each diesel generator in parallel operation. *More T4800 units interconnected with a 2-wire cable.*

When applied with the B9300 Power Reference Unit, one or several generators can be operated in parallel with the grid.

T4900 VAR Load Sharer

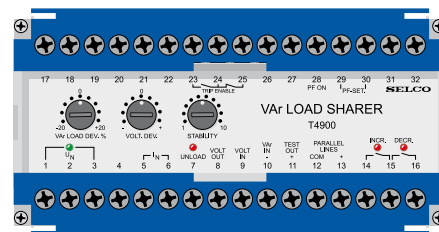

The T4900 provides automatic reactive load sharing (VAR) and system voltage control for parallel running generators.

The reactive load and voltage are measured on each generator, compared with the other generators and corrected via the E7800 Motorized Potentiometer or T7900 Electronic Potentiometer, until balance is obtained. The T4900 can also be used for power factor ($\cos \phi$) control in parallel operation with the grid. One unit is required for each generator.

T5000 Paralleling Relay

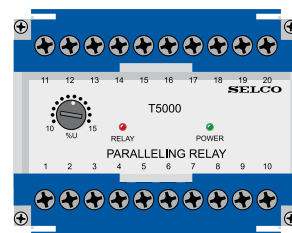

The T5000 can be used as a synchronizing aid or as a check synchronizer. It will give a closing signal to the generator circuit breaker when voltage difference, phase difference and frequency difference are within safe limits, thus preventing damage or disturbance to the power plant.

E7800 Motorized Potentiometer

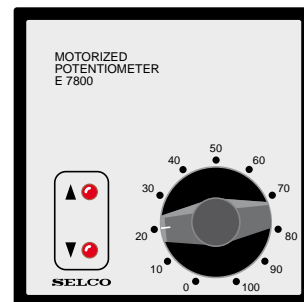

The E7800 can be used as an intermediate unit between the electronic speed controller and the SELCO automatic synchronizers or load sharers. For voltage regulation it can be applied with the T4900 VAR Load Sharer.

The E7800 Motorized Potentiometer can also be used as an individual stand-alone unit for many industrial applications.

Available for AC or DC supply with the DC versions being equipped with a step motor for adjustable speed. Flush mounted unit with standard measurements of 96 x 96 x 75mm.

M8100 Synchroscope

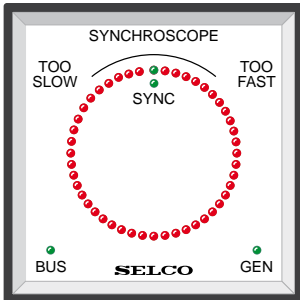

The M8100 provides illuminated indication of the actual phase difference between generator voltage and busbar voltage.

When obtaining phase accordance, the two green LEDs at 12 o'clock will indicate and the generator circuit breaker can be closed.

The unit can be supplied with an optional integrated paralleling relay.

Flush mounted unit with standard measurements of 96 x 96 x 80mm.

B9300 Power Reference Unit



The B9300 is applied in connection with SELCO Load Sharers T4400 and T4800, when running in parallel with the grid (utility).

The unit determines the power to be supplied from the generators to the grid, adjustable 0-100%.

Flush mounted unit with standard measurements of 96 x 96 x 75mm.

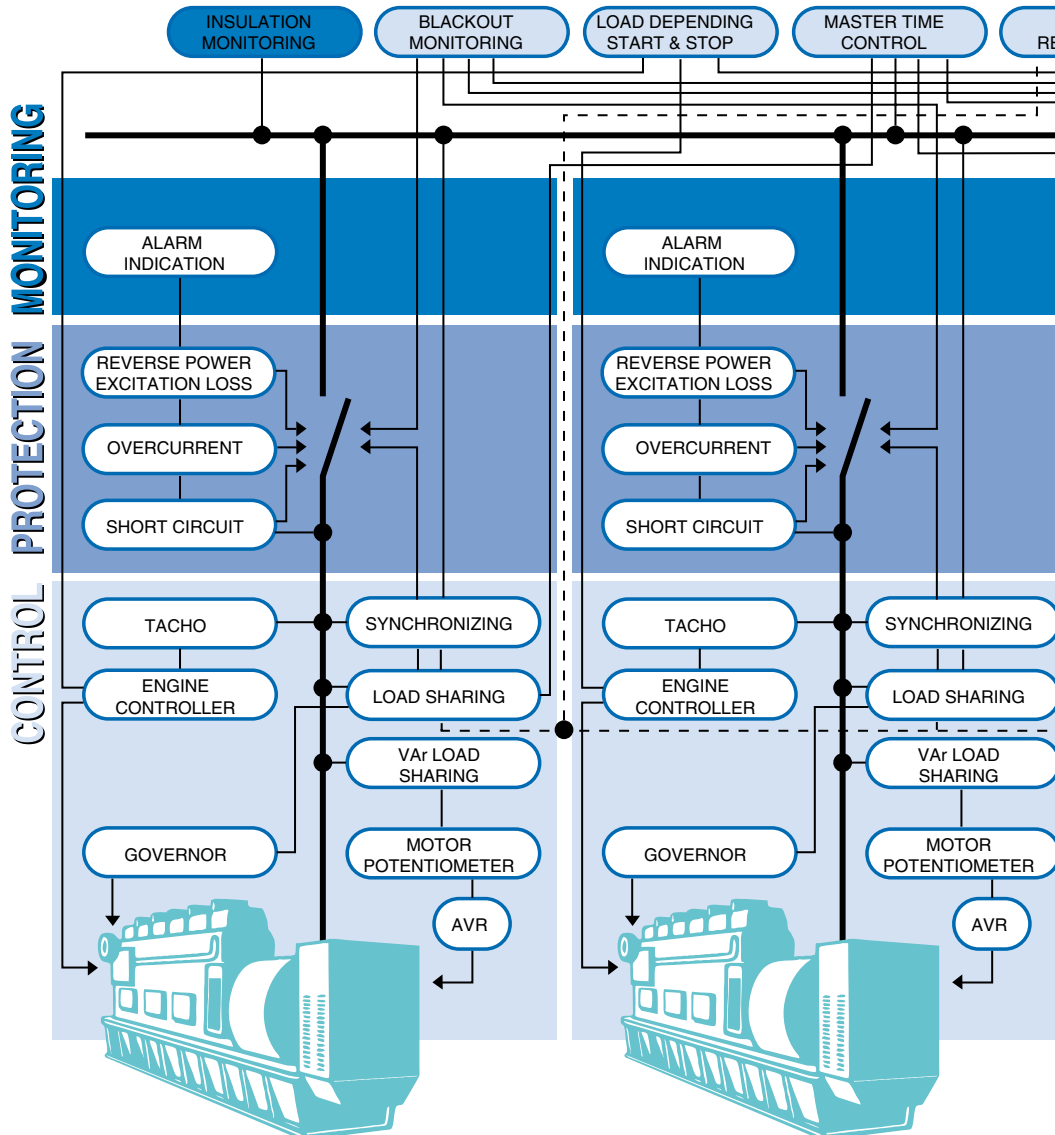

Typical equipment applied for three diesel generators and one shaft generator

T7900 Electronic Potentiometer

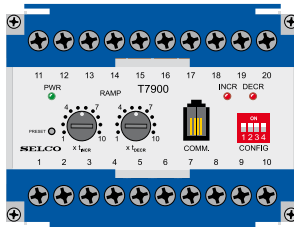

The T7900 Electronic Potentiometer is typically used as an interface between increase and decrease contacts and a device requiring control / adjustment by a voltage or current signal, such as an electronic speed controller.

In such applications, the T7900 acts similar to a motorized potentiometer, only the output can be a voltage, a current or a pulse width modulated signal (PWM), while the motorized potentiometer has a resistor output. Basic configuration is easily done by standard dials and dip switches while advanced configuration is accessible by PC. The PC configuration is done by a standard ANSI terminal in clear text. The T7900 can also be used as a programmable power reference unit (like the SELCO B9300). The power reference facility provides programmable increase/decrease ramps as well as eight pre-programmable target settings. A 0-10 VDC output is also provided for remote indication of the output level (0-100 %).

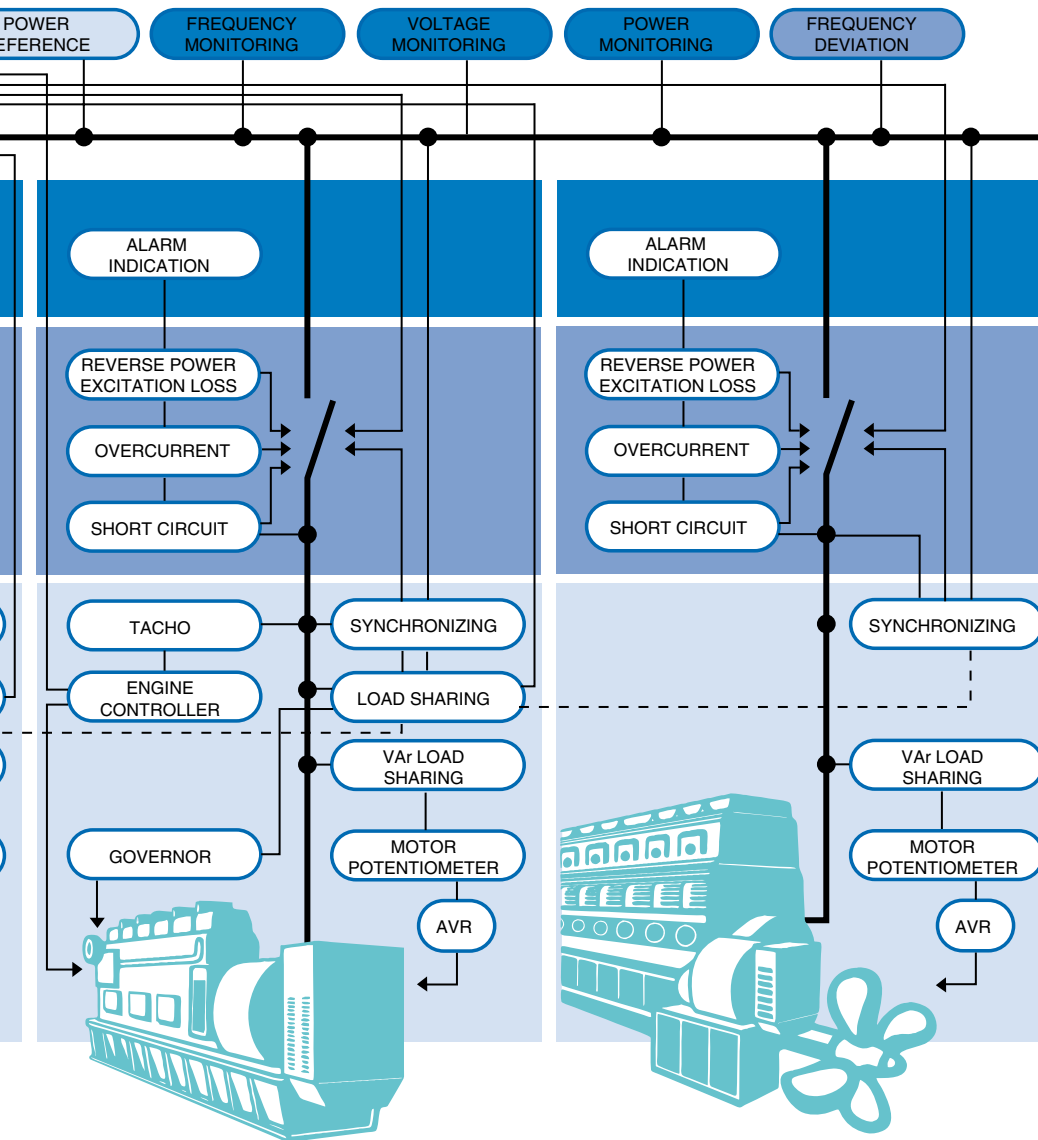

Generator protection and power monitoring

The Selco T-line range also includes a wide selection of protection relays and units for monitoring of the bus-bar and generator voltage, frequency and insulation, as well as detection of blackout.

The trip levels and the delays before trip are easily adjustable using dials at the front cover. Some units also furnish an adjustable hysteresis setting.

T2000 Reverse Power Relay

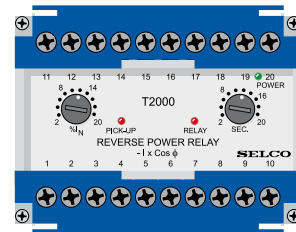

The T2000 will, during parallel operation, prevent the generator from running as a motor, thus protecting the prime mover e.g. a diesel engine and unloading the remaining generators by tripping the generator breaker.

T2100 Excitation Loss Relay

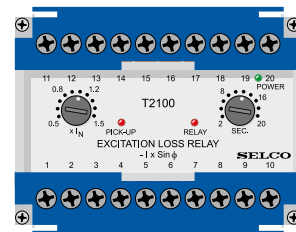

The T2100 protects against partial or complete excitation loss on the synchronous generator. If a generator under parallel operation has a low excitation, a high inductive current is running into the generator. This current is detected and the faulty generator breaker is tripped, thus avoiding overload on the other generators with a possible blackout of the system.

T2200 3 Phase Overcurrent Relay

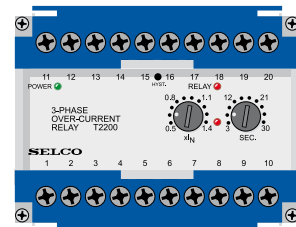

The T2200 has a broad application, where all 3 phases or any single phase current detection will function as protection, control or monitoring. The relay detects the highest of the 3 input currents and, when the preset value is exceeded, an output relay will be activated after a preset time delay.

Complete Protection of Generators

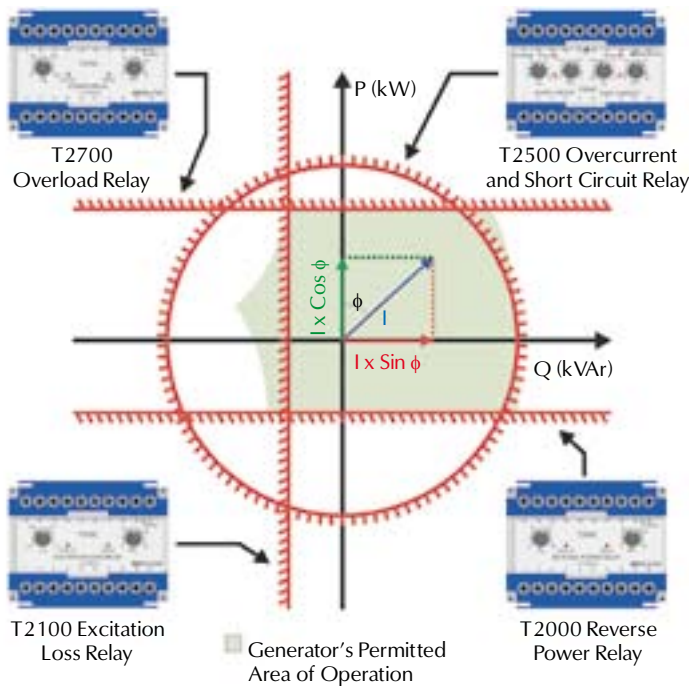

This figure illustrates the complete protection of a generator. The green shaded area illustrates the permitted area of operation for a generator. This information is normally supplied by the generator manufacturer.

The vertical axis represents the active power, and the horizontal axis represents the reactive power. The active power is represented by $I \times \cos \Phi$. The T2700 Power Relay measures $I \times \cos \Phi$, and when it becomes too high, the relay will trip, indicated by the upper horizontal red line.

The Reverse Power relay measures $-I \times \cos \Phi$, representing the active power in the negative direction, and it will trip for reverse power. The T2100 Excitation Loss Relay measures $-I \times \sin \Phi$, representing the reactive power in negative direction, and it will trip when exceeding the level represented by the red vertical line.

The T2500 Overcurrent and Short Circuit Relay measures the magnitude of the current and thus protects against current levels outside the area of the red circle.

T2300 3 Phase Short Circuit Relay

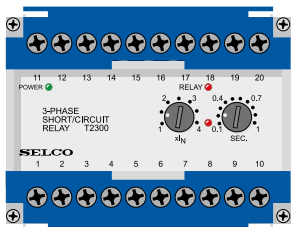

The T2300 is intended for protection of generators, power transmissions and consumer supply against damage caused from short circuit by tripping the circuit breaker.

The relay detects the highest of the 3 input currents and, when the preset value is exceeded, an output relay will be activated instantly (100 msec.) or after a preset time delay.

T2400 3 Phase Dual Overcurrent Relay

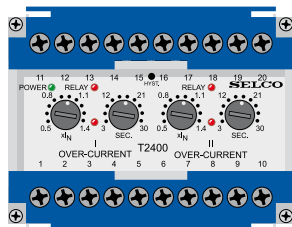

The T2400 furnishes 2 combined over-current relays, intended for protection or monitoring of generators, power transmissions and consumer supply.

A typical generator application is to let one of the overcurrent functions trip the generator breaker and to let the other overcurrent function trip a nonessential service. Both overcurrent functions could be used to trip 2 levels of nonessential loads. (Widely used in marine applications)

The relay detects the highest of the 3 input currents and, when the preset values are exceeded the output relays will be activated after preset time delays.

T2500 3 Phase Overcurrent and Short Circuit Relay

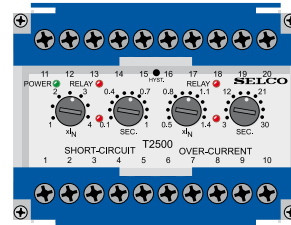

The T2500 is intended for protection of generators, power transmissions and consumer supply against thermal damage and faults caused by high currents, with consequent tripping of the system breaker.

The relay detects the highest of the 3 input currents and, when the preset values are exceeded, the output relay will be activated after preset time delays.

T2600 Dual Current Relay

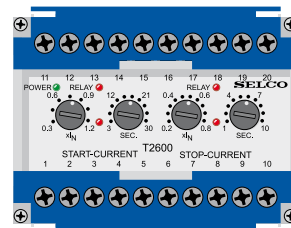

The T2600 determines load depending start and stop levels of a standby diesel generator. When load increases on the running diesel generators more than e.g. 90%, adjustable, for a preset time, a start signal to call for the standby diesel generator will be provided. If the load decreases below e.g. 45%, adjustable, for a preset time, a stop signal will be provided to stop the standby diesel generator.

The T2600 can serve an installation with up to 3 diesel generators. With an extension unit additional generators can be served.

T2700 Power Relay

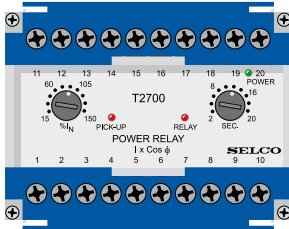

The T2700 is intended for detection of power level for protection, control and monitoring purposes. The relay detects the magnitude of the power and, when the preset value is exceeded, an output relay will be activated after a preset time delay.

T3000 Frequency Relay

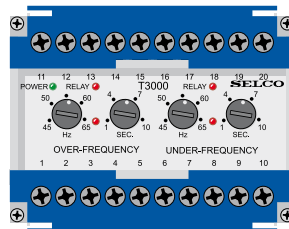

The T3000 is intended for effective frequency monitoring on generators, busbars or other distribution systems. The relay contains the functions "under frequency" and "over frequency", time delayed, and 2 individual output relays, one relay for each function.

T3200 Insulation Monitor

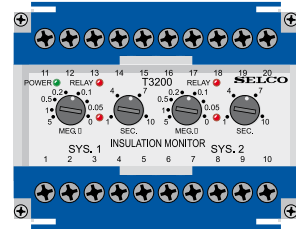

The T3200 is intended for continuous insulation monitoring on 3 phase insulated networks on board ships. The relay continuously monitors two systems galvanically separated from each other, e.g. the busbar and the lighting system or two busbar systems.

T2800 Overcurrent or Earth Fault Relay

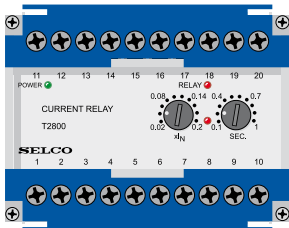

The T2800 has a broad application as an earth fault or a single phase overcurrent detection relay. It has a wide setting range for protection, control or monitoring. The relay detects the magnitude of the current and, when the preset value is exceeded, an output relay will be activated after a preset time delay.

T3100 and T3300 Voltage Relays

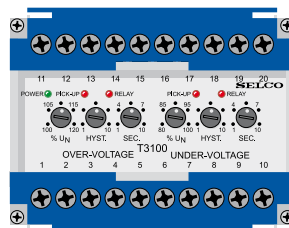

The T3100 and T3300 are intended for effective voltage monitoring on generators, busbars or other distribution systems. The relays contain the functions "under voltage" and "over voltage", time delayed, and 2 individual output relays, one for each function.

T3100 is for monitoring on one phase and T3300 is for 3 phase monitoring.

The unit features two output relays for alarm purposes and two analog outputs for instrument readings.

T3500 Frequency Deviation Relay

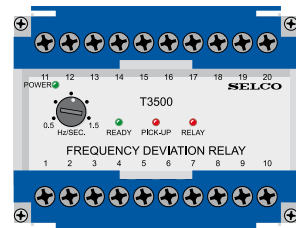

Rate of change of frequency (ROCOF) relay, df/dt relay. The T3500 will monitor the frequency of the connected busbar. In case there is a rapid change of frequency, the relay will trip.

T2900 3 Phase Differential Current Relay

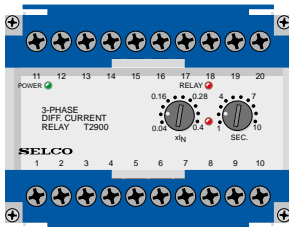

The T2900 3 Phase Differential Relay is intended as a protection relay for generators, power transmissions and consumer's supply by tripping the main circuit breaker.

The T2900 measures the differential current of each of the 3 phases. The relay detects the highest of the 3 input currents and, when the preset values are exceeded, the output relay will be activated after preset time delays.

T8400 Blackout Limiter

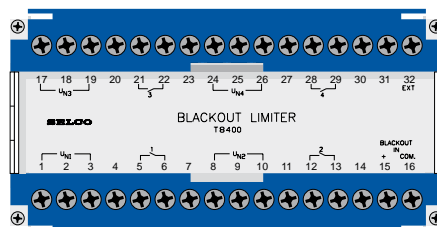

The T8400 enables fast clearing of a blackout. If a blackout occurs, the first generator to have more than 90 % voltage will make the generator breaker close. It is possible to monitor up to 4 generators with 1 unit, and up to 8 generators with 2 units.

We are SELCO

Since the origin in 1960, SELCO technology has provided the electrical power generation market with high class equipment, living up to the major international standards.

Generator Control, Protection & Monitoring

- Generator protection:
Short circuit, overcurrent, reverse power, excitation loss, engine protection.
- Generator controls:
Synchronizing, frequency control, active and reactive load sharing, load control, power management, engine control.
- Generator monitoring:
Voltage, frequency, power, insulation.



The SELCO equipment has been thoroughly tested by certified laboratories with regard to high vibration levels, heat, cold, humidity, salt mist, EMC emission and immunity as well as other parameters.

SELCO products are in accordance with all significant international standards and have been approved and certified by the major marine classification societies.

SELCO Worldwide



- SELCO Denmark
- SELCO subsidiary
- SELCO representation

Main Office:
 SELCO A/S
 Betonvej 10
 DK- 4000 Roskilde
 Denmark
 Phone: + 45 - 70 26 11 22
 Fax: + 45 - 70 26 25 22
 e-mail: selco.dk@selco.com
 www.selco.com

